

CF SERIES

ALUMINIUM COMPRESSED AIR FILTERS

operating pressure	20 bar
volume flow rate	72 to 2760 Nm³/h
connections	3/8" to 3"
operating temp. range	1,5 to 65 °C
standard colour	RAL 5012

APPLICATIONS

- general industrial applications
- automotive
- electronics
- food and beverage
- chemical
- petrochemical
- plastics
- paint

DESCRIPTION

CF filter housings are designed for high efficient removal of solid particles, water, oil aerosols, hydrocarbons, odour vapours from compressed air⁽¹⁾ systems. To meet the required compressed air quality appropriate filter element (B, P, R, M, S, A) must be installed into filter housing.

⁽¹⁾ For any other technical gas please contact producer or your local distributor.

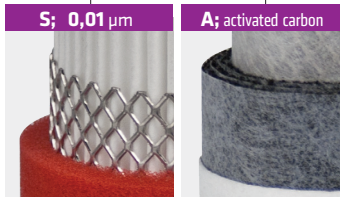
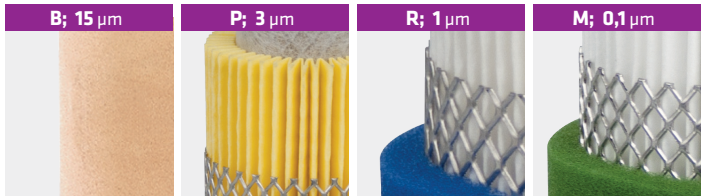
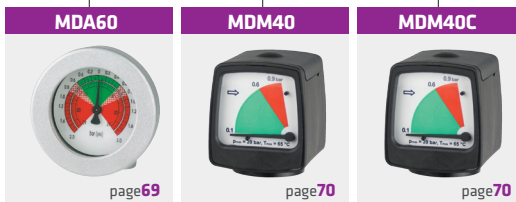

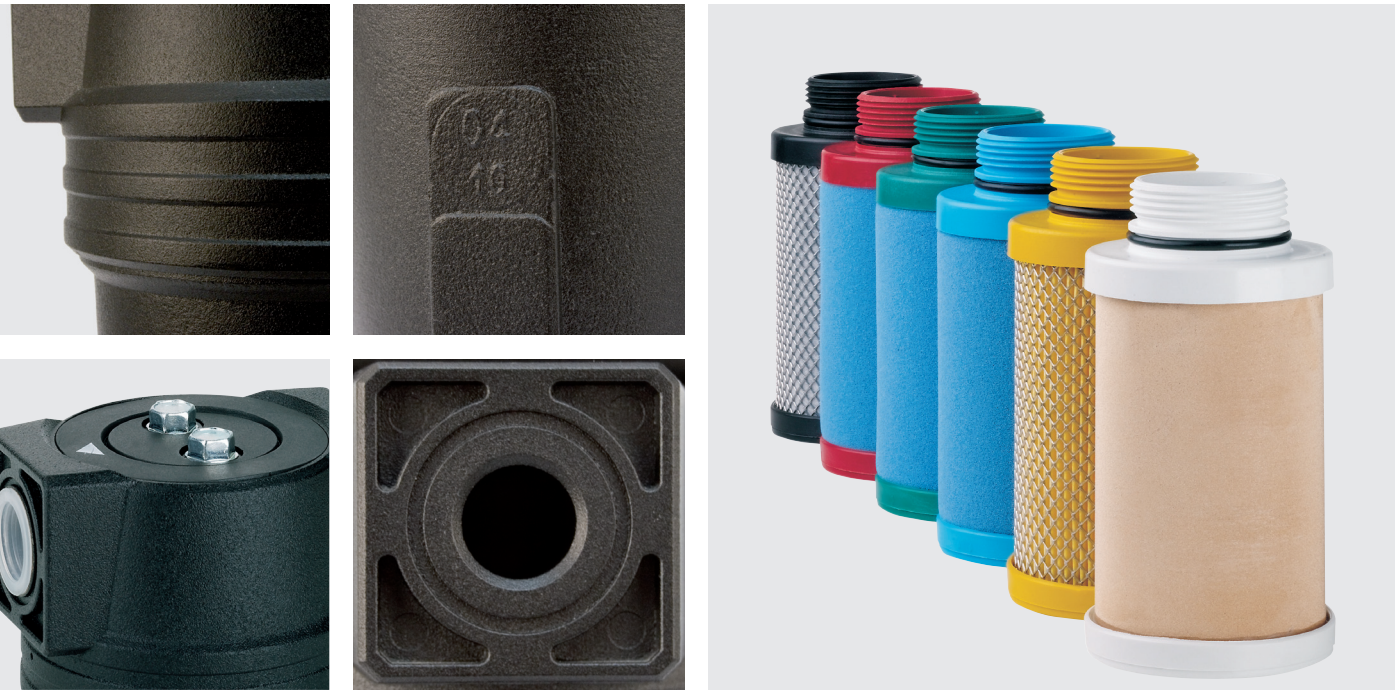

TECHNICAL DATA										FILTER ELEMENTS					
Filter housing size	Pipe size	Max. oper. pressure	Flow rate at 7 bar(g), 20 °C		Dimensions [mm]				Mass	B sintered 15 µm	P prefilter 3 µm	R prefilter 1 µm	M microfilter 0,1 µm	S microfilter 0,01 µm	A activated carbon
	inch		bar/psi	Nm³/h	scfm	A	B	C		D	kg				
CF 20	3/8"	20/290	72	42	187	88	20	80	0,7	20 CB	20 CP	20 CR	20 CM	20 CS	20 CA
CF 21	1/2"	20/290	96	56	256	88	20	80	0,8	21 CB	21 CP	21 CR	21 CM	21 CS	21 CA
CF 30	1/2"	20/290	150	88	278	106	25	100	1,3	30 CB	30 CP	30 CR	30 CM	30 CS	30 CA
CF 31	3/4"	20/290	216	127	278	106	25	100	1,3	31 CB	31 CP	31 CR	31 CM	31 CS	31 CA
CF 40	1"	20/290	282	166	252	125	32	120	2,1	40 CB	40 CP	40 CR	40 CM	40 CS	40 CA
CF 41	1"	20/290	360	212	352	125	32	140	2,4	41 CB	41 CP	41 CR	41 CM	41 CS	41 CA
CF 42	1 1/4"	20/290	432	254	352	125	32	140	2,4	42 CB	42 CP	42 CR	42 CM	42 CS	42 CA
CF 43	1 1/2"	20/290	510	300	450	125	32	160	3,2	43 CB	43 CP	43 CR	43 CM	43 CS	43 CA
CF 44	1 1/2"	20/290	750	441	450	125	32	160	3,2	44 CB	44 CP	44 CR	44 CM	44 CS	44 CA
CF 50	2"	20/290	888	522	605	160	43	180	5,1	50 CB	50 CP	50 CR	50 CM	50 CS	50 CA
CF 51	2"	20/290	1176	692	605	160	43	180	5,1	51 CB	51 CP	51 CR	51 CM	51 CS	51 CA
CF 52	2 1/2"	20/290	1440	847	685	160	43	200	6,3	52 CB	52 CP	52 CR	52 CM	52 CS	52 CA
CF 60	3"	20/290	1968	1158	800	240	60	300	12,9	60 CB	60 CP	60 CR	60 CM	60 CS	60 CA
CF 61	3"	20/290	2760	1624	800	240	60	300	12,9	61 CB	61 CP	61 CR	61 CM	61 CS	61 CA

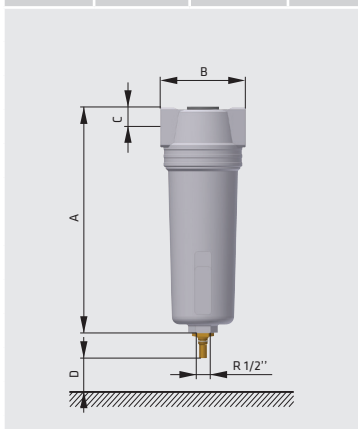

quality class - solids (ISO 8573-1)	7	6	3	2	1	1 ³⁾
residual oil content [mg/m³]	-	-	-	<0,1	<0,01	<0,005
quality class - oils (ISO 8573-1)	-	-	-	2	1	1
pressure drop - new element [mbar / psi]	20 / 0,290	10 / 0,145	20 / 0,290	50 / 0,725	80 / 1,160	60 / 0,870
change filter cartridge at pressure drop [mbar / psi]	¹⁾	350 / 5,07	350 / 5,07	350 / 5,07	350 / 5,07	6 months ²⁾
filter media	sintered brass	acrylic fibres, cellulose	borosilicate micro fibres			activated carbon
pleated version	-	✓	✓	✓	✓	-
wrapped version	-	-	-	-	-	✓
sintered version	✓	-	-	-	-	-
min. operating temperature (°C / °F)	1,5 / 35	1,5 / 35	1,5 / 35	1,5 / 35	1,5 / 35	1,5 / 35
max. operating temperature (°C / °F)	65 / 149	65 / 149	65 / 149	65 / 149	65 / 149	45 / 113

CORRECTION FACTORS																			
Operating pressure [bar]	2	3	4	5	6	7	8	9	10	11	12	13	14	15	16	17	18	19	20
Operating pressure [psi]	29	44	58	72	87	100	115	130	145	160	174	189	203	218	232	247	261	276	290
Correction factor	0,38	0,50	0,63	0,75	0,88	1	1,13	1,25	1,38	1,50	1,63	1,75	1,88	2,00	2,13	2,25	2,38	2,50	2,63

¹⁾ B filter element can be cleaned with ultrasonic bath or with back flushing. Intervals of cleaning depends of application. If necessary replace filter element with new one.
²⁾ Filter elements "A", must be changed periodically to suit application, but at least every 6 months. Activated carbon filters must not operate in oil saturated conditions.
³⁾ Valid if "S" filter cartridge is installed upstream.